

MDS iNET 900™

Wireless IP/Ethernet
Connectivity

industrial wireless PERFORMANCE



FEATURES/BENEFITS

- Simultaneously Handles Multiple Protocols/Applications/Users – over one radio or over one network
- Serial Gateway – allows migration to IP from existing serial networks
- Industrial Grade Performance – UL Class 1 Div 2* & Extended temperature range for extreme environments
- Industrial Grade IP/Ethernet
- Long Range – Up to 30 miles
- High Speed – Up to 512 Kbps
- Secure – Multiple security levels; preventing eavesdropping or unauthorized access
- Deploy Today – License free
- Plug and Play Connectivity – configuration requires virtually no setup

APPLICATIONS

- Wireless Ethernet
- Gateway to MDS BluNET™ and other short-range networks
- Gateway for serial/legacy networks and/or devices to IP network
- Video and/or Voice-over-IP
- Portable network access for vehicle based operation

MDS...Global wireless solutions. Industrial Wireless Performance.

For over 15 years, Microwave Data Systems (MDS) has been providing wireless networking solutions with applications in SCADA, telemetry, telecommunications, and online transaction markets. MDS provides licensed and unlicensed solutions, with more than 500,000 radios installed in over 110 countries.

Introducing MDS iNET 900™

The MDS iNET 900™ is a long-range, high-speed, industrial, wireless IP/Ethernet solution. It allows customers to bring business information over Ethernet or a serial gateway and onto networks. This includes mission-critical, revenue-generating data from fixed assets such as oil and gas wells, compressor stations, pipelines, fluid storage tanks and utility meters. It also enables portable network access for vehicle based operation.

MDS iNET 900 is available in three configurations:

Access Point/Remote Dual Gateway, which provides both serial and Ethernet connections, and is configurable by the customer as either an access point or a dual gateway.

Remote Serial Gateway, which provides two serial ports and allows serial to IP migration.

Remote Ethernet Bridge, which provides ethernet connectivity - with the ability to drop to multiple devices.

MDS iNET 900 uses advanced 900 MHz FHSS technology for license-free operation in the 902-928 MHz ISM band. It is capable of up to 30 mile range and up to 512 kbps data rate for IP/Ethernet communications. This product is available for use in Class I, Division 2, Groups A, B, C & D hazardous locations.*

Why use an MDS iNET 900 Wireless Networking Solution?

Longest range industrial product in its class. Providing lowest cost of ownership.

Future proof. We use open standards architecture design, and upgradeable firmware to ensure customer investment protection over the long-term.

MDS NETview MST™ Network Management System is based on a platform independent Java application. It is application independent with a centralized SNMP server and integrates with multiple vendor platforms.

Secure wireless operation with multiple layers of protection, including 900 MHz FHSS physical layer and data encryption.

Flexible. The MDS iNET 900 supports multiple users connecting to multiple applications via multiple protocols on the same MDS iNET 900 or the same network - simultaneously!

industrial/wireless/performance



MDS iNET 900™ Specifications

General

Data Rate	512/256 Kbps user configurable air link 1,200-115,200 bps serial ports
Frequency Band	902-928 MHz ISM band
Spreading Mode	Frequency Hopping Spread Spectrum
Coverage Range	Up to 30 mi. (40 Km.)
Configurations	Access Point/Remote Dual Gateway Configurable by customer as access point or dual gateway (serial and Ethernet/IP connections) Remote Serial Gateway 2 serial port connections Remote Ethernet Bridge 1 Ethernet connection with multidrop capability

Physical Interface

Ethernet	10BaseT, RJ-45
Serial	RS-232/V.24, DB-9F, DCE RS-232/V.24, DB-9M, DTE
Antenna	TNC connector (female)
LEDs	Lan, Com1, Com2, Power, Link

Protocols

Wireless	CSMA/CA Wireless Protocol with Collision Avoidance
Ethernet	IEEE 802.3 Spanning Tree (Bridging) IP (DHCP, ICMP, UDP, TCP, ARP)
Serial	Clear channel mode for serial async multidrop protocols including Modbus, DNP.3, DF1, BSAP.

Radio

Carrier Power	0.1 to 1 watt (20 to 30 dBm)
Output impedance	50 Ohms
Occupied Bandwidth	316.5 kHz
Modulation	CPFSK (Continuous Phase FSK)
Receiver Sensitivity	-92 dBm @ 512 Kbps with 10 ⁻⁶ BER -100 dBm @ 256 Kbps with 10 ⁻⁶ BER

Management

HTTP (embedded web server)
SNMPv1, MIB II, Enterprise MIB
Text-based menu interface on serial port Telnet
MDS NETview MS™

Environmental

Temperature	-30°C to +60°C (-22°F to +140°F)
Humidity	95% at 40°C (104°F) non-condensing
Input Power	10.5-30 Vdc (13.8 Vdc nominal)
Ext. power supply	48 Vdc, 110/220 Vac
Current Consumption	Rx: 2.8 W from 10.5 to 24 Vdc Rx: 3.5 W from 24.5 to 30 Vdc Tx: 8 W from 10.5 to 24 Vdc Tx: 9 W from 24.5 to 30 Vdc

Mechanical

Case	Die Cast Aluminum
Dimensions	3.15 H x 17.2 W x 11.2 D cm (1.25 H x 6.75 W x 4.5 D in.)
Weight	908 g (2 lb.)
External interfaces	BluNET™
Mounting options	Flat surface mount brackets, DIN rail, 19" rack (1U high)

Agency Approvals

FCC Part 15 approved
UL Class 1 Div. 2 approved* (UL 508, UL 1604)
IC approved
CSA Pending

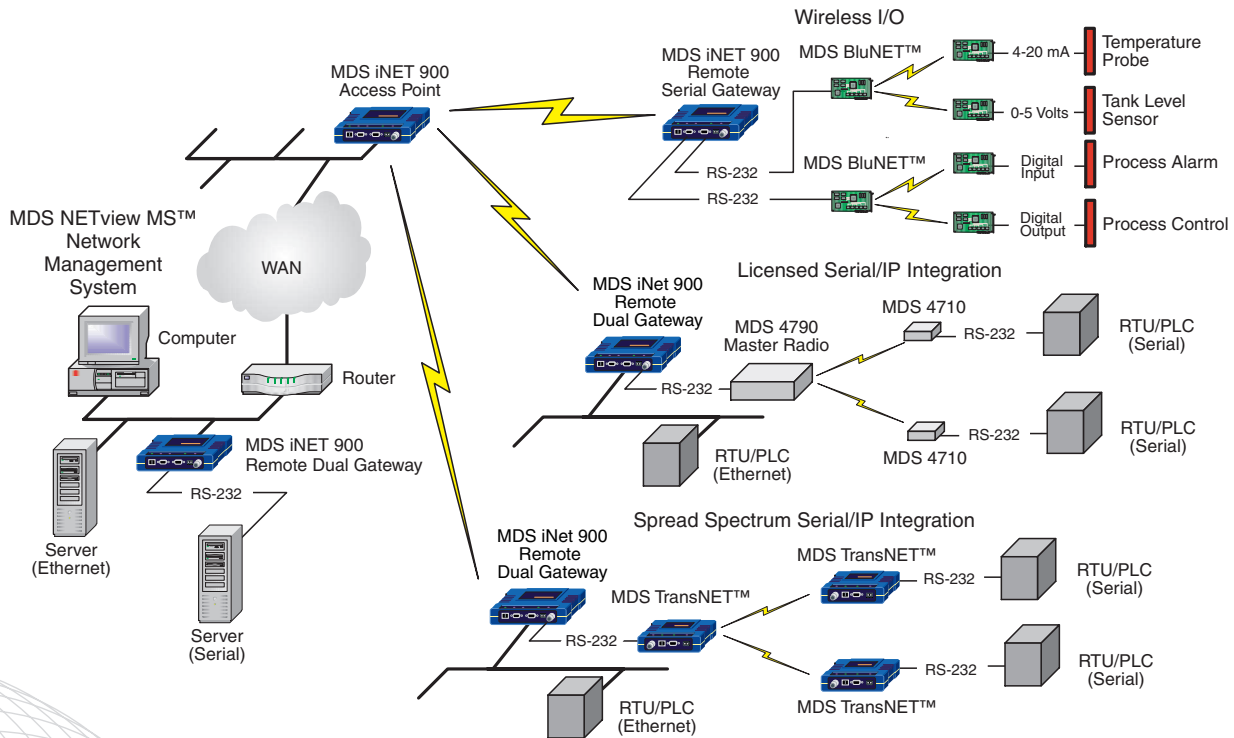

* The transceiver is not acceptable as a stand-alone unit for use in the hazardous locations described above. It must either be mounted within another piece of equipment, which is certified for hazardous locations, or installed within guidelines, or conditions of approval, as set forth by the approving agencies.

industrial/wireless/performance



MICROWAVE DATA SYSTEMS INC.
175 SCIENCE PARKWAY
ROCHESTER, NEW YORK 14620, USA
PHONE (585) 242-9600
FAX (585) 242-9620
WWW.MICROWAVEDATA.COM

MDS products are manufactured under a quality system certified to ISO 9001. MDS reserves the right to make changes to specifications of products described in this data sheet at any time without notice and without obligation to notify any person of such changes.
© 2001 MDS Inc. (MDS iNET 900 SL0093) Rev. J, 06-21-02